

Industrial Amplifiers

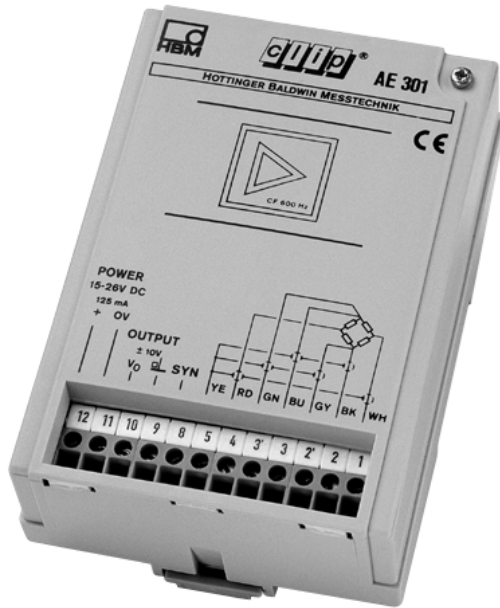

Special features

- Amplifier and additional units for strain gauge full bridges and inductive half and full bridges
- Modules for mounting onto support rails to DIN EN 50022
- Accuracy class 0.1
- Adjustment via DIP switches and potentiometers
- Clip IG industrial amplifier (aluminium-die-cast enclosure) IP65
- Intrinsically safe EEx ib measurement circuit with safety barriers

Dimensions (in mm; 1 mm= 0.03937 inches)

Clip Electronics

AE101
AE301
AE501/AE511
EM201
EM201K2
GR201
DA101
TS101

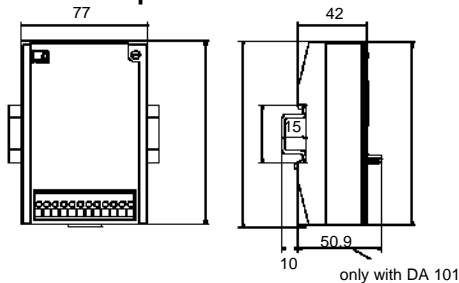

NT101A
NT102A

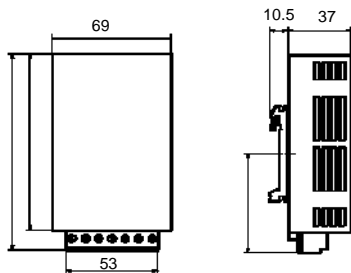

Clip IG Industrial amplifier

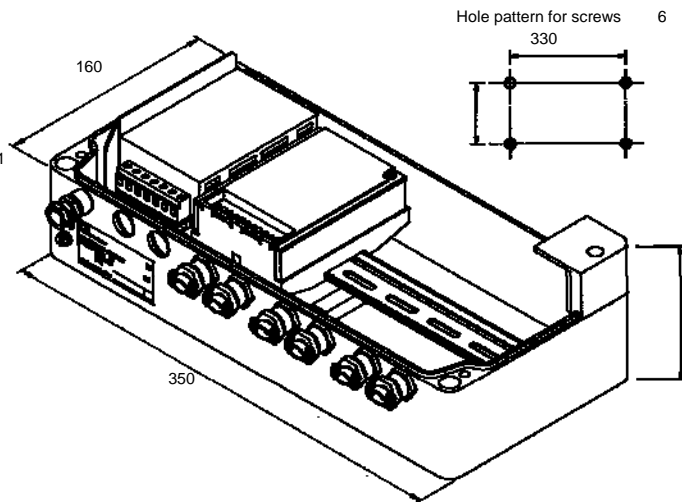

Specifications

Clip IG Industrial amplifier in aluminium-die-cast enclosure

Degree of protection		IP65
Weight approx.	kg	4.3
Weight (empty)	kg	3.2
Ambient temperature	°C [°F]	-20...+50 [-4...+122]
Operating voltage with 101A Power supply unit (Type WG 010) with NT 102A Power supply unit (Type WG 011)	V V	230 **10 % 115 **10 %
Mechanical stress (test similar to DIN IEC 68) Vibration (30 min each direction)	m/s ²	50 (5...65 Hz)
Impact (3 times each direction, impact duration 6ms)	m/s ²	350

AE101, AE 301, AE501 Measuring amplifiers for support rail mounting

Type		AE101	AE301	AE501
Accuracy class		0.1	0.1	0.1
Transducers that may be connected Strain gauge full bridge V _E = 10 V V _E = 5 V V _E = 2.5 V	Ω Ω Ω	340...5000 170...5000 85...5000	– 170...5000 85...5000	– – –
Inductive half/full bridge V _E = 2.5 V V _E = 1 V	mH mH	– –	– –	2.5...20 6...19
Bridge excitation voltage V_E (symmetrical to earth)	V V V	10 5 2.5	5 2.5 –	2.5 1 –
Permissible cable length between transducer and amplifier	m		500	
Carrier frequency (crystal-stabilised)	Hz	– DC	600	4800
Bridge zero balance coarse approx. fine approx.	mV/V mV/V	** 2 ** 0.08	** 2 ¹⁾ ** 0.09	** 80 ** 3.2
Measuring ranges V _E = 10 V V _E = 5 V V _E = 2.5 V V _E = 1 V	mV/V mV/V mV/V mV/V	0.1...2 0.2...4 0.4...8 –	– 0.2...4 ²⁾ 0.4...8 ³⁾ –	– – 8...160 20...400
Calibration signal , in addition to the meas. signal	mV/V	+ 0.2 ** 1 %		+ 8 ** 1 %
Input impedance	MΩ	>10 / 2 nF	> 1 / 3 nF	> 1 / 2nF
Common mode voltage, max. perm.	V _{pp}	** 10 V		
Common mode rejection 0... 300 Hz > 300 Hz	dB dB	> 100 > 85	> 100 –	
Linearity deviation	% full scale	< 0.05 typ 0.03		
Output voltage Rise rate, max.	V V/μs	** 10 0.4	** 10 –	
Load resistance	kΩ	≥ 4		
Internal resistance	Ω	< 2		

¹⁾ AE301S6 and AE301S7: **1 coarse, **0.05 fine

²⁾ AE301S6 and AE301S7: 0.1...2

³⁾ AE301S6 and AE301S7: 0.2...4

Specifications

AE101, AE 301, AE501 Industrial amplifiers

Type		AE101	AE301	AE501
Measuring frequency range Bessel 3rd-order low-pass filter. changeover (-1 dB) Bessel 3rd-order low-pass filter (-1 dB)	Hz kHz Hz	0...10 0...6 -	- - 0...10 ⁴⁾	- - 0...10
Phase transit time with 0...10 Hz filter with 0...6 kHz filter	ms µs	< 18 < 20	< 17 ⁵⁾ -	< 17 -
Rise time with 0...10 Hz filter	ms	25		
Overshoot in the case of voltage surge with 0...10 Hz filter with 0...6 kHz filter	% %	0 < 10	< 2 -	
Noise voltage measuring range 0.2 mV/V (10 Hz) measuring range 2 mV/V (10 Hz) measuring range 8 mV/V (10 Hz) measuring range 80 mV/V (10 Hz) measuring range 0.2 mV/V (6 kHz) measuring range 2 mV/V (6 kHz)	mV _{rms} mV _{rms} mV _{rms} mV _{rms} mV _{rms} mV _{rms}	< 4 < 4 - - < 30 < 6	< 4 < 4 - - - -	- - < 4 < 4 - -
Long term drift over 48 hours (after 1 h warm-up time)	µV/V	< 0.2	< 0.1	< 0.8
Influence of a 10 K-change in ambient temperature on sensitivity on zero point measuring range 0.2 mV/V measuring range 2 mV/V measuring range 8 mV/V (1 mV/V) measuring range 10 mV/V measuring range 80 mV/V (10 mV/V)	% full scale mV mV mV mV mV	 < 60 < 10 - - -	< 0.1 typ 0.05 < 10 < 4 -	
Influence of a +15...26 V change in operating voltage on sensitivity on zero point (350 Ω bridge resistance)	mV mV	< 1 < 1		
5V-synchronisation (square wave)	kHz	-	76.8	
Residual carrier voltage	mV	-	< 5	
Operating voltage (DC)	V _{DC}	+15...26		
Power consumption	mA	≤ 125		≤ 100
Nominal temperature range	°C [°F]	-20...+60 [-4...+140]		
Service temperature range	°C [°F]	-20...+60 [-4...+140]		
Storage temperature range	°C [°F]	-25...+70 [-13...+158]		
Degree of protection		IP20		
Weight	g	200		

⁴⁾ AE301S6: 0...2 (-1 dB)

AE301S7: 0...60 (-1 dB)

⁵⁾ AE301S6: <80 (filter frequency 2 Hz)

AE301S7: <2.8 (filter frequency 60 Hz)

TS101 Tare and store unit

Type		TS101
Accuracy class		0.1
Input voltage	V	**10
Input impedance	kΩ	100
Output voltage	V	**10

Specifications

TS101 Tare and store unit

Permissible load resistance	k Ω	≥ 5
Linearity deviation	%	< 0.04 of full scale
Influence of a 10 K-change of the ambient temperature	%	< 0.1 of full scale
Influence of a 15...26 V-change of the operating voltage	%	< 0.01 of full scale
Long-term drift over 48h (after 1 hour warm-up time)	%	< 0.02 of full scale
Noise voltage of the output	mV _{pp}	< 20
Control inputs (floating)		
High signal level	V	11...30 (24 V nominal)
Low signal level	V	0...5
Control output		
High signal level	V	V _b -2
Low signal level	V	<1
Output current	mA	<500
Tare unit		
Output	ms	Net value (alternatively pos. peak val.)
Net-value amplification		1, 2, 5, 10-fold, selectable in steps, for taring of major initial loads
Tare error (with $v=1$)	mV	<4
Settling time for the output voltage after taring	ms	40 (to 99.9 %)
Low-pass filter (before taring)	Hz	0.1...12.5; adjustable
Transmission bandwidth	kHz	>10
Storage time for tare value		Unlimited as long as V _b is present (alternatively, storage in EEPROM)
Control input		Taring with rising edge
Delay time for taring	ms	<1
Control output		Taring valid
Peak-value store unit		
Output		Peak value (alternatively, pos./neg. peak, peak/peak 0.5 x peak/peak or instantaneous value or envelope-curve value, tared and amplified (1, 2, 5, 10-fold))
Peak-value store update-rate	ms	<1.3
Accuracy	%	0.25 (in 6 ms)
	%	0.05 (in 20 ms)
Transmission bandwidth	Hz	15 (-1 dB)
Settling time for the output voltage	ms	40 (to 99.9 %)
Discharge rate for envelope curve	mV/s	5...1000, adjustable
Control inputs		Run/Hold; (clear/inst.value)
Delay time for the control signals	ms	<8
Connection		12 series terminals for wire \varnothing 0.13...1.5 mm ² ; 10 mm end sleeves for strands
Operating voltage V_b	V _{DC}	15...26, unstabilized
Power consumption	mA	<90
Nominal temperature range	°C [°F]	-20 to +60 [-4...+140]
Service temperature range	°C [°F]	-20 to +60 [-4...+140]
Storage temperature range	°C [°F]	-25 to +70 [-13...+158]
Weight	g	ca. 200
Degree of protection to EN60529		IP20
Mounting		On support rails to EN 50022

EM201 Output stage module (with one EM002 module)
EM201K2 Output stage module (with two EM002 modules)

Accuracy class		0.1
Input Voltage Impedance	V kΩ	** 10 (0...+ 10 V) > 11.5
Operating voltage	V _{DC}	+15...26
Power consumption (fully assembled with 2 x EM002)	mA	< 180
Nominal temperature range	°C [°F]	- 20...+ 60 [-4...+140]
Service temperature range	°C [°F]	- 20...+ 60 [-4...+140]
Storage temperature range	°C [°F]	- 25...+ 75 [-13...+158]
Weight	g	200

EM002			
Output signal selectable	mA	** 20	4...20
Output current with V _E =10 V with V _E = 0	mA mA	20 **0.02 < ** 0.04	20 **0.5 4 ** 0.2
Output current limit	-	-	> 3 (switchable)
Permissible load resistance	Ω	< 500	
Linearity deviation	%	< 0.05 full scale	
Internal resistance	kΩ	> 100	
Measuring frequency range	kHz	3 (-1 dB)	
Degree of protection		IP20	

GR201 Limit value switch

Accuracy class		0.1
Differential input Voltage Impedance	V kΩ	** 10 > 50
Reference voltage coarse approx. fine approx.	V V	** 10 ** 0.5
Switching hysteresis Factory setting: R43, R48 to be changed by R43 and R48	mV kΩ kΩ	220 3.01 670 mV / V _{Hyst.}
Influence of a 10K-change in ambient temperature on the switching point	%	< 0.05 full scale
Switching-point error	%	< 0.05 full scale
Relay capacity max. voltage max. current	V A W	45 (separated extra low voltage) 1 30 (25 VA)

Specifications

GR201 Limit value switch

Switching times (Factory setting)		
Response time	ms	< 5
Decay time	ms	< 25
Operating voltage	V _{DC}	+15...26
Power consumption	mA	< 100
Nominal temperature range	°C [°F]	- 20...+ 60 [-4...+140]
Service temperature range	°C [°F]	- 20...+ 60 [-4...+140]
Storage temperature range	°C [°F]	- 25...+ 70 [-13...+158]
Degree of protection		IP20
Weight	g	200

NT 101A, NT 102A*) Power supply

Type		NT101A	NT102A
Input voltage	V	230 ** 10 %	115 ** 10 %
Permissible frequency range	Hz	47...63	
Output voltage	V _{DC}	15.3	
Output current I_n at >25°...+60°	A _{DC}	0.45	
Output power	W	9.75	
Efficiency approx.	%	60	
Current limiter (protected against sustained short circuit)		1.2 x I _n (permanently adjusted)	
Residual ripple	mV _{pp}	≤ 10	
Ambient temperature	°C [°F]	- 20...+ 60 [-4...+140]	
Excess-temperature protection	°C [°F]	typ.105 [221] (trafo temperature)	
Test voltage	kV _{eff}	3.75 (prim/sec and prim/housing)	
Degree of protection		IP20	
Weight	g	420	

*) Version to DIN –VDE0551, EN60742 Protection class 1

Clip accessories:

Covering angle 3-6450.0001

Clip IG accessories:

Bag with accessories 2-9278.0339 anti-buckling sockets, earth sleeves and end sleeves for strands for connection of one cable. End sleeves for strands (0,5 mm², 10 mm long).



measurement with confidence